

Order Number
11-03-0044
Engineering Number
HT60630B

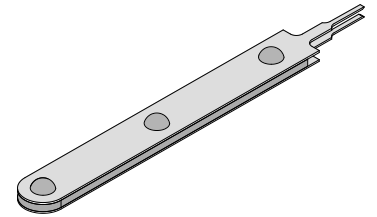

Application Tooling Specification



FEATURES

- This tool is designed to extract crimped Mini-Fit series terminals from their housings.

SCOPE

Products: Mini-Fit Jr., Mini-Fit HCS and Mini-Fit Plus HCS Male and Female Crimp Terminals, 14-30 AWG and 2.00mm (.079") Pitch Board-In Male Crimp Terminals, 24-28 AWG.

Terminal Series No.	Terminal Order No.							
5556	39-00-0038	39-00-0039	39-00-0046	39-00-0047	39-00-0055	39-00-0056	39-00-0059	39-00-0060
	39-00-0065	39-00-0066	39-00-0073	39-00-0074	39-00-0077	39-00-0078	39-00-0079	39-00-0080
	39-00-0089	39-00-0090	39-00-0093	39-00-0094	39-00-0108	39-00-0109	39-00-0110	39-00-0111
	39-00-0112	39-00-0113	39-00-0114	39-00-0115	39-00-0116	39-00-0117	39-00-0118	39-00-0119
	39-00-0141	39-00-0142	39-00-0153	39-00-0154	39-00-0157	39-00-0158	39-00-0163	39-00-0164
	39-00-0167	39-00-0168	39-00-0169	39-00-0170	39-00-0173	39-00-0174	39-00-0175	39-00-0176
	39-00-0179	39-00-0180	39-00-0181	39-00-0182	39-00-0183	39-00-0184	39-00-0185	39-00-0186
	39-00-0194	39-00-0195	39-00-0198	39-00-0200	39-00-0201	39-00-0204	39-00-0205	39-00-0207
	39-00-0208	39-00-0211	39-00-0212	39-00-0213	39-00-0214	39-00-0217	39-00-0218	39-00-0405
	39-00-0406	39-00-0410	39-00-0419	39-00-0425	39-00-0428	39-00-0429	39-00-0434	39-00-0435
	39-00-0436	39-00-0440	39-00-0441	39-00-0447	39-00-0448	40-13-0851	40-13-0852	39-00-0139
39-00-0140	39-00-0091	39-00-0092						
5558	39-00-0040	39-00-0041	39-00-0048	39-00-0049	39-00-0053	39-00-0054	39-00-0061	39-00-0062
	39-00-0067	39-00-0068	39-00-0075	39-00-0076	39-00-0081	39-00-0082	39-00-0083	39-00-0084
	39-00-0095	39-00-0096	39-00-0099	39-00-0100	39-00-0120	39-00-0121	39-00-0122	39-00-0123
	39-00-0124	39-00-0125	39-00-0126	39-00-0127	39-00-0128	39-00-0129	39-00-0130	39-00-0131
	39-00-0147	39-00-0148	39-00-0219	39-00-0220	39-00-0223	39-00-0224	39-00-0411	39-00-0420
	39-00-0426	39-00-0430	39-00-0431	39-00-0432	39-00-0433	39-00-0437	39-00-0449	39-00-0450
	40-13-0853	40-13-0854						
30490	30490-1002	30490-1012	30490-2002	30490-2012	30490-9802	30490-9902		
44476	44476-1111	44476-1112	44476-1211	44476-1212	44476-3111	44476-3112	44476-3211	44476-3212
	44476-9901	44476-9902	44476-9903	44476-9904	44476-9905	44476-9906	44476-9907	44476-9908
44478	44478-1111	44478-1112	44478-1221	44478-1122	44478-1211	44478-1212	44478-1121	44478-1222
	44478-3111	44478-3112	44478-3121	44478-3122	44478-3211	44478-3212	44478-3221	44478-3222
	44478-9901	44478-9902	44478-9903	44478-9904	44478-9905	44478-9906	44478-9907	44478-9908
44485	44485-1211	44485-1212	44485-1311	44485-1312	44485-1411	44485-1412	44485-2211	44485-2212
	44485-2311	44485-2312	44485-2411	44485-2412	44485-3211	44485-3212	44485-3311	44485-3312
	44485-3411	44485-3412	44485-5211	44485-5212	44485-5311	44485-5312	44485-5411	44485-5412
45750	45750-1111	45750-1112	45750-1211	45750-1212	45750-3111	45750-3112	45750-3211	45750-3212
	45750-4111	45750-4112	45750-4211	45750-4212				
46012	46012-1141	46012-1142	46012-1241	46012-1242	46012-3141	46012-3142	46012-3151	46012-3152
	46012-3161	46012-3241	46012-3242	46012-3251	46012-3252			
46018	46018-1541	46018-1542	46018-2541	46018-2542	46018-3541	46018-3542		
46083	46083-1111	46083-1112	46083-1121	46083-1122	46083-1211	46083-1212	46083-1221	46083-1222
	46083-2111	46083-2112	46083-2121	46083-2122	46083-2211	46083-2212	46083-2221	46083-2222
	46083-3111	46083-3112	46083-3121	46083-3122	46083-3211	46083-3212	46083-3221	46083-3222
46098	46098-1541	46098-1542	46098-2541	46098-2542	46098-3541	46098-3542		
5378	39-00-0029	39-00-0030						

OPERATION

1. Insert the extraction tool into the housing as shown in Figure 1.
2. Use the slots located on the inside of the housing to guide the extraction tool blades into the housing until contact is made with terminal.
3. Continue to insert the tool, always checking to see that the blades of extraction tool are on the outside of the contact, as shown in Figure 2.
4. Continue to insert extraction tool into housing until the locking tangs have snapped out of their locked position. If the terminal locking tabs are still not totally depressed, hold on tight to the wire and push it toward the extraction tool. This will completely depress the locking tabs. See Figure 2.
5. Grasp the terminal by the wire, and gently pull it out from the housing.

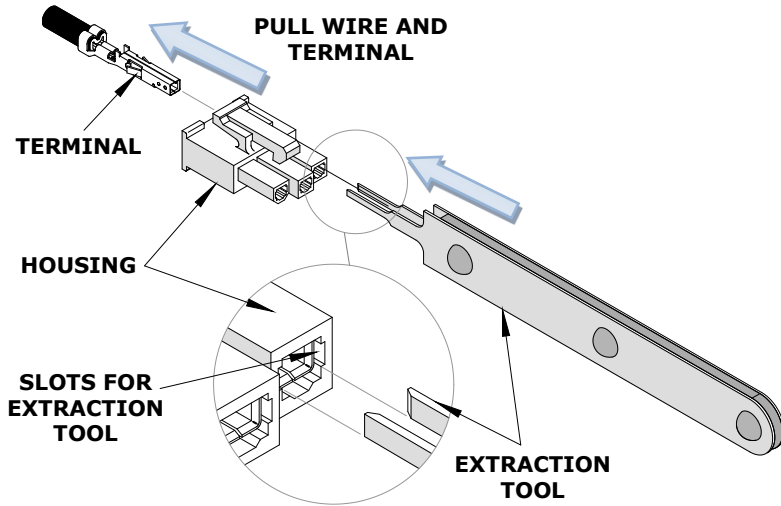
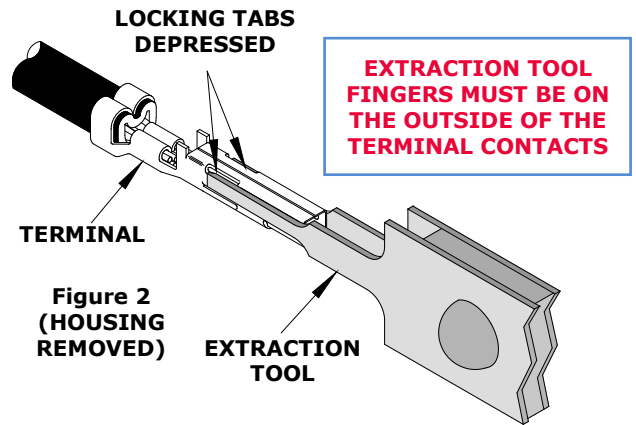

Figure 1



Terminal and Housing Application Chart		
Terminal Series No.	Used with Housing Series No.	Use Extraction Tool No. 63813-1200 <u>Only</u> for these Terminal and Housing Combinations.
44478-**2*	44157	
44476	44156	

Note: When a terminal is removed in this manner the locking tangs are damaged and the terminal is not reusable.

For 5378 Terminal Series

Individual terminals may be extracted from the housing using this tool.

1. Hold the housing with the locking tab facing up. Bend the wire down and insert one of the blades of the extraction tool into the housing under the locking tab. See Figure 3.
2. Hold the wire against the extraction tool and gently pull the terminal by the wire and the extraction tool at the same time out from the housing in the direction shown.

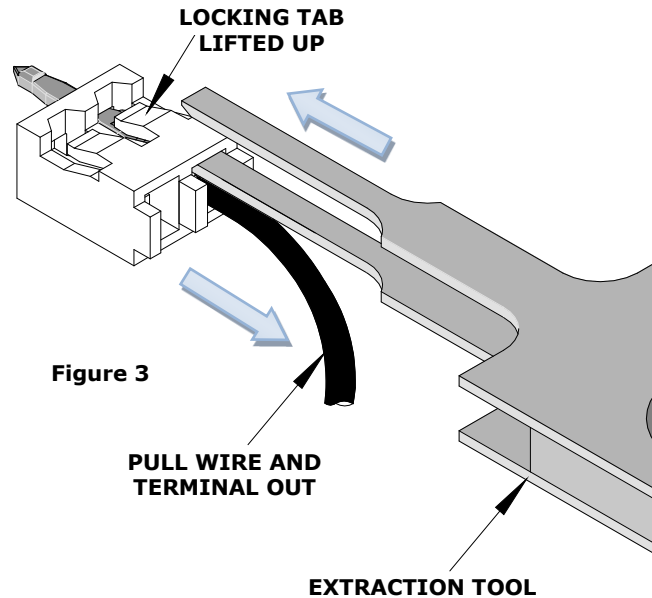

Note: Molex does not offer repair parts for extraction tools due to the inexpensive nature of these tools.

CAUTION: This extraction tool should be used to extract the terminal only. Using it for unintended purposes may cause injury or damage to parts. Be careful not to deform the end of the terminal.

CAUTION: Molex specifications are valid only when used with Molex terminals, applicators and tooling.

Application Tooling Support

Phone: (402) 458-TOOL (8665)

E-Mail: toolingsupport@molex.com

Website: www.molex.com/applicationtooling

Molex is a registered trademark of Molex, LLC in the United States of America and may be registered in other countries; all other trademarks listed herein belong to their respective owners.